

# S4T238SW-707 SERIES SPEED GATE OPERATING MANUAL



## Contents

1. Product Introduction.....	2
2. Testing Before Installation.....	3
3. Installation.....	3
4. Drive Board Wiring.....	6
5. Operation Explanation.....	9
6. Regular Maintenance.....	10
7. Warranty and Service.....	11
8. Package Items.....	11
9. Appendix .....	12

Thank you very much for buying the intelligent speed gate produced by our company. kindly read this manual before installation and operating, and please note after working long time, the control board would heat up slightly and this is a normal phenomenon. Please make sure all these parts cool before doing the routine maintenance.



# 1. Product Introduction

Description	Parameters
Lane Width	560-900mm
IP	IP54
Pass Speed	25-30 persons/min
Power supply	AC220V/110V,50/60Hz
Drive Mode	Motor drive
Max Power Consumption	200W
Opening time	0.06S
Humidity	≤90% coagulation free
Noise	≤50dB
Service Life	3,000,000 cycles
Outside packing	145x110x24cm
Working Environment	-20° C~+60° C
Gross Weight	85KGS

## DIMENSION:

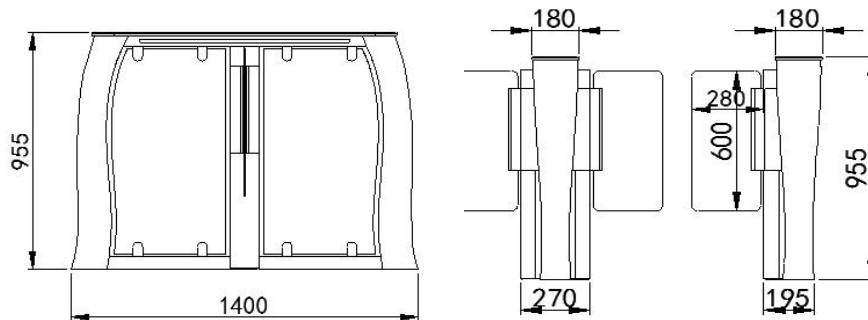

Picture1-1

### 1 ALARM BUZZER DETECTION FOR UNAUTHORIZED USAGE

Alarm buzzer function will be triggered when the user is passing thru without authorization , tail gaiting or incorrect direction.

### 2 ELEGANT DESIGN

Slim form factor, premium stainless steel and glass panel material with elegant arc design effectively help create an welcoming and elegant prestigious atmosphere at building entrance to impress your visitors.

### 3 DOUBLE SAFETY

Door will automatically reverse once safety IR detected obstacle or when a small force is detected blocking its motion. This dual detection feature is to prevent injury caused by door hitting people.

### 4 EASY INTEGRATION

A push button or access control reader can be used to trigger the swing barrier to open via simple dry contact signal. After delay timer elapsed, swing barrier will automatically close back by itself.

### 5 MINIMUM MAINTENANC

Uses brushless DC motor eliminate the need of changing carbon brush thus reducing maintenance work. Key internal parts is treated with anti-rust and anti-septic to ensure long term reliability.

### 6 EMERGENCY RECOVERY

During power failure, swing barrier will automatically open for free pass through. This will fast escape in the event of emergency. When the power resume, swing barrier will automatically close back.

## 2. Testing before installation

### 2.1 Process:

- 1.Power on the device with AC110V/220V(Notice:the earth must be connected).
- 2.Wait 30 seconds until the device finishes self-detection.
- 3.Check the wing opening in both directions,and check the LED.If it works fine,start installation

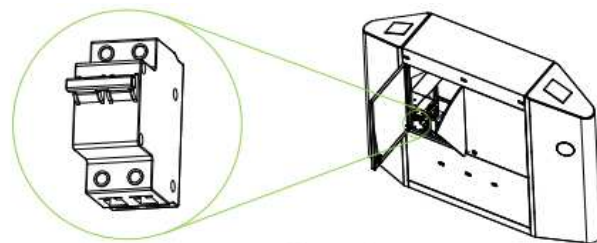

Air Switch

Picture 2-1

## 3. Installation

### 3.1 Conditions and the location

The installation base must be solid to ensure that the expansion screws are well mounted to fix the devices. Confirm the installation position.

**BDS707-A is only for one-lane use. For two-lane or more, please combine BDS708-A.**

If the speed gate is close to the wall, a space of 100mm distance between the device and the wall should be reserved in order to open the cover and change the setting.

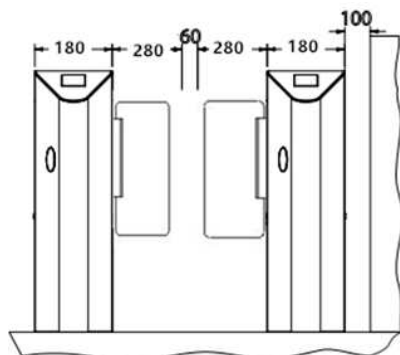

Picture 3-1A One Lane

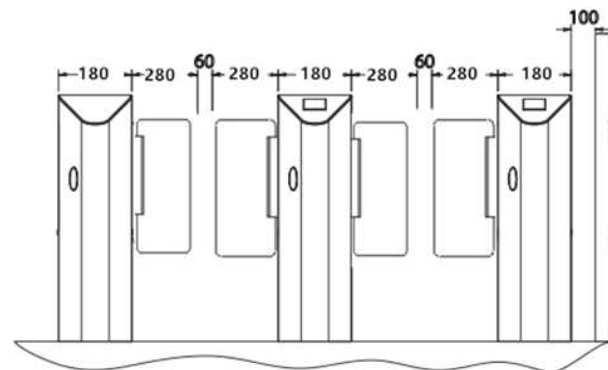

Picture 3-1B Two Lanes

### 3.2 Wiring

Regarding to the wiring position, please check picture 3-2.

Please use the 3 PINs wires including earth wire for power. In order to avoid jamming between high voltage and communication wire, it is recommended to separate these two kinds of wire in different pipes. The earth must be connected.

### 3.3 Installation

#### Process

1. Power on the master device and slave device, ensure the 6 pairs of sensor on both sides are fitted. The distance between two wings should be 60mm when they are in closed status.
2. Mark the position of the device and the holes for expansion screws.
3. Drill holes on the marked position. The holes should be 14mm diameter and 80mm depth.

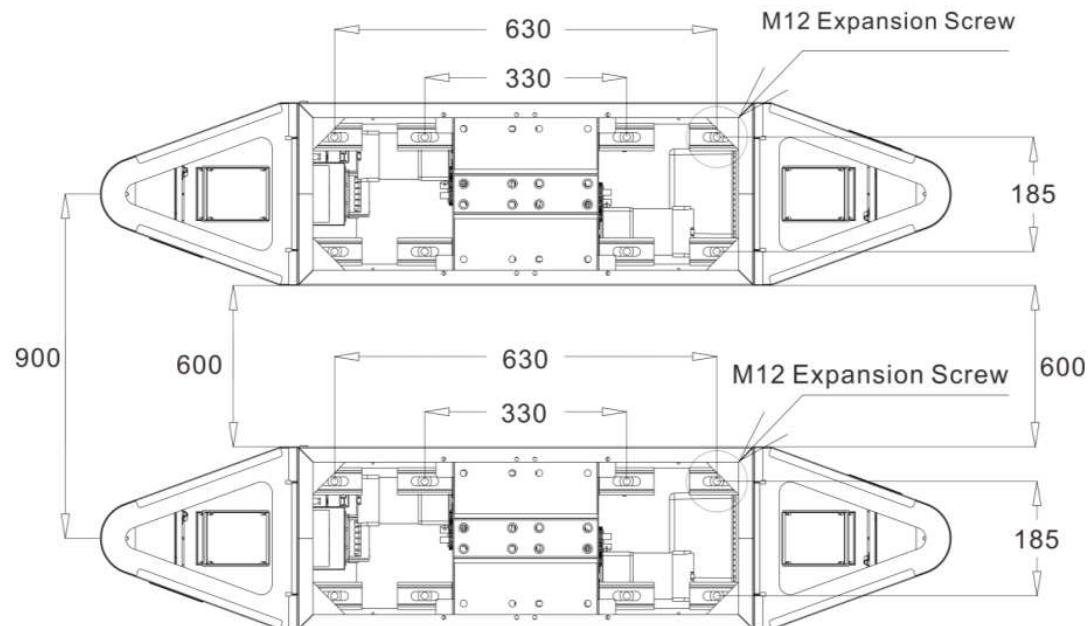

Picture 3-2

4. Put the glue on the expansion screws and put into the holes. Put the speed gate device on the proper position. Ensure that the device is horizontally installed.

Note: There must be 8 expansion screws for each side.

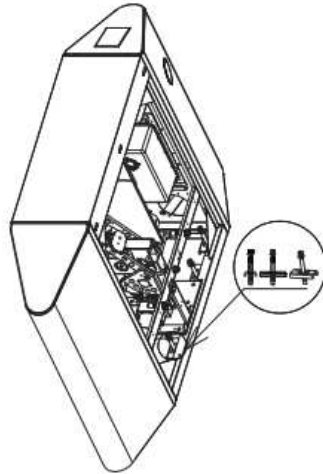

Picture 3-3

### 3.4 Set Reminding Line

It is recommended to set the reminding line on the ground. The user will stay out of the reminding line to swipe card or press fingerprint.

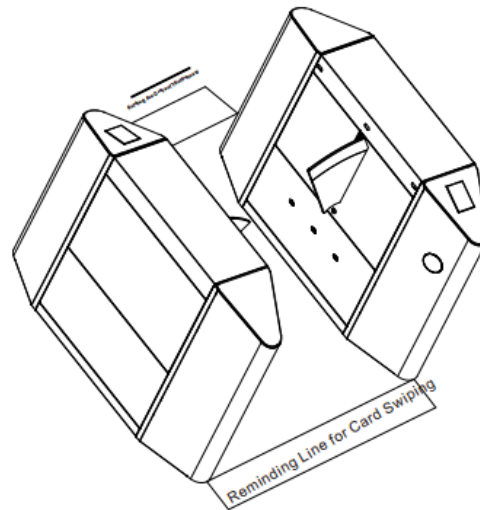

Picture 3-4

## 4. Drive Board Wiring

### 4.1 Drive board description

Speed gate drive board, air switch, power supply were included in a stainless box, fixed inside of the housing, box size is: 350mm(L)\*220(W)\*65(H)mm, there are wiring posts on the box for drive board.

1-5 wiring posts for user input (for access control system etc); down end wiring posts for speed gate wing position detection inputs (connected), 1-9 wiring posts for IR sensors detection inputs (connected).

Note: 8 core cable wiring the master device and slave device synchronization inputs keep them works fine.

### 4.2 Unlock input

1# unlock input, 2# unlock input and GND: gate opening input interface, receive dry contact signal to open the gate. There are two pairs of input for both in and out. That means access control system need two relays to indicate in and out.

ALM: Alarm input for normal open.

XF: Emergency input for normal open, for example fire alarm input.

### 4.3 Wing's position detection input

There are +12V, A, B inputs detecting wing's position;

+12V, A, GND: use for detecting speed gate is unlock status;

+12V, B, GND: use for detecting speed gate is lock status;

The function of limited switch: control the motor start direction, right is A lighting, left is B lighting.

Z is encoder output, used for control the middle position, (Z turned off means receiving signal), used for control the clutch.

### 4.4 IR sensor detection input

There are 3 pairs IR sensor input, each pair included 3 inputs, used for wiring with first (for entry&exit detection), second (installed in the middle of the housing), third (for entry&exit detection). Totally 5 pairs IR sensor detection input (1# to 5#), standard device only used 1#, 3#, 5# inputs, others are expand input.

IR sensor inputs: 12V, IR1, GND, 12V, IR3, GND, 12V, IR5, GND

#### 4.5 Other input

+MOT-: connect to motor's "+ "and "-" ; 24V,SOL1: connect to clutch;

1、 GND、 2: housing top green LED indicator output; R1:housing top red LED indicator,illegal entry will be lighting;

NC1、 NO1、 GND、 NO2、 NC2:connect to housing side LED direction indicators,showing passages the direction available or not.

+24-: for power supply.

#### 4.6 Connection between Access control system

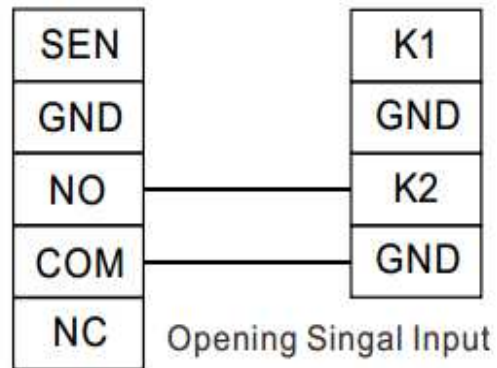

Access Control System

Picture 4-3

**Note: The access control relay open duration should be no more than 1 second.**

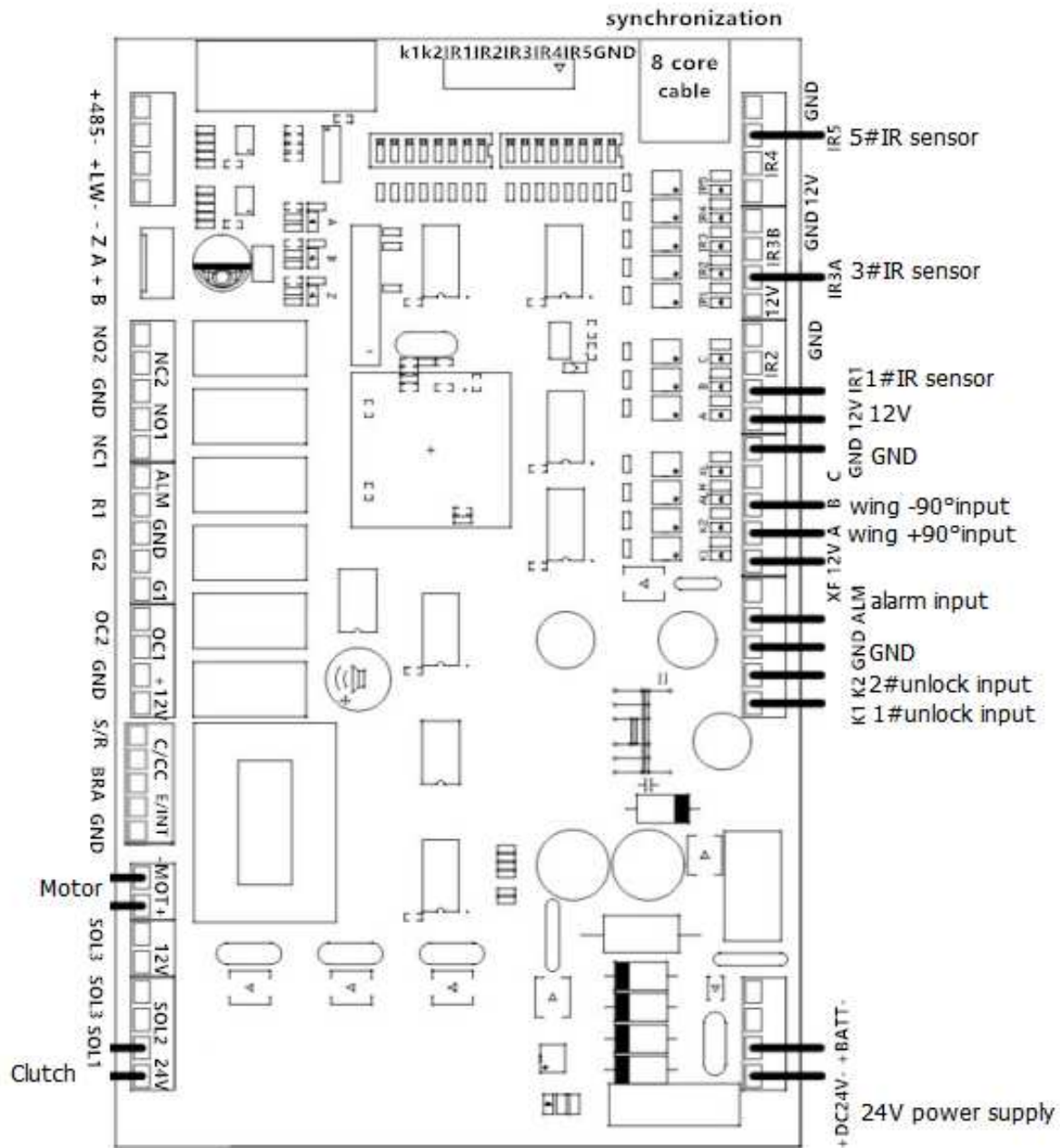

Picture4-4

security4all.ro

## 4.6 DIP Switch Setting

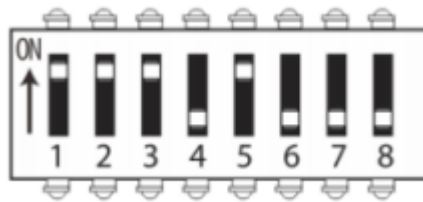

(1=ON 0=OFF)

Picture4-5

No.	SW1-1	SW1-2	SW1-3	SW1-4	SW1-5	SW1-6	SW1-7	SW1-8
Function	Open speed		Open direction			Alarm	Opening time	
Default	1	0	1	0	0	0	0	0

Note: SW1-1 and SW1-2 adjust open speed: 00 01 10 11 = (fourth third second first) speed

SW1-3 adjust gate unlock direction,used for synchronize two pieces gates

SW1-4 electromagnet z point,SW1-5 encoder z point

SW1-6 stop the alarm

SW1-7 and SW1-8 adjust open time: 00 01 10 11 =5s 3s 8s 10s

## 4.7 Indicators

Power、K1、K2、ALM、XF、A、B、C、IR1、IR2、IR3、IR4、IR5 indicating power supply、1# unlock input、2# unlock input、unlocking status、locking status、1、2、3、4、5 pairs IR sensors detected signal.

# 5. Operation Explanation

## 5.1 Operation principle

- 1).When power on,the gate is normally locking;
- 2).When access signal activated, the gate will be unlock;
- 3).When power off or emergency signal is activated,the gate open automatically;
- 4).When authorized access signal is sent, the gate will lock within fixed time if there is no passenger access.

## 5.2 The working mode

In order to facilitate the user, there are multiple working modes for the user to choose according to the actual situation of usage.

- 1).Bi-directional card reading and staff limiting
- 2).Left can read the card , while right can be forbidden to pass
- 3).Right can read the card , while left can be forbidden to pass

## 6. Regular Maintenance

### 6.1 Maintenance

1.The housing of the equipment is of a sub-polish stainless steel,It is required to clean regularly with soft cloth so as to keep a clean and polish surface.It is forbidden to clean the surface with a hard object;otherwise,the appearance maybe affected.It is also forbidden to wash it with water,otherwise,short circuit may occur in the electric control system and the equipment may be damaged.Ensure that the power supply is disconnected before the inspection to avoid electric shock.

2.It is required to check regularly the connection of various movement sections of the equipment.Fasten timely the loose fasteners such as nut and screw,otherwise,turnstile failure maybe resulted due to long term cooperation.

3.It is required to check regularly the protection grounding of the system to ensure a reliable connection.

4.It is required to check regularly the connectors and line connection points to ensure a reliable connection.

### 6.2 Common failures and the remedy

1. No indication for LED and counter,and not able to read card after power on.

The failure is due to power system,it is required to check carefully the power supply or the 5A fuse in the drive board of the equipment for damage,and see if there exists any loose connector or broken power line.

2.Not available to read card normally.

The failure is mainly due to a loose connection between reading device and the main controller or the reading device maybe damaged.Replace the reading device and carry out functional test for it.

3. Unable to unlock the gate.

The failure is mainly due to main controller or drive board, replace the control board and carry out functional test for it. Check the K1 and K2 LED indicator lighting or not.

Check the IR sensor LED IR1 IR3 IR5

Check the MOT input with power or not

4. The wing hit the housing.

The failure is mainly due to limited switch damaged, check the limited switch LED indicator lighting or not.

5. The wings are not in the same line.

The failure is mainly due to the encoder, adjust the encoder.

## 7. Warranty and Service

1. 1 year warranty
2. Service for all the year with due charge accordingly
3. 24 hours online service

The circumstances of the following will not offer free warranty:

1. The user does not operate the product according to the manual, which causes the product to be broken.
2. Using the product in the conditions of unstable current, overload current or not in line with the national electricity standard
3. The user mismanages the product and causes the product problem.
4. Product damage is because of natural disaster.
5. Not in the warranty period.
6. Other services promised by distributors.

The manufacturer reserves the explanation rights to the manual and the warranty articles.

## 8. Package Items

Item	Name	Qty	Unit	Notes
1	Housing	1	Pc	Necessary
2	Wing	1	Pc	Necessary
3	Mechanism	1	Pc	Necessary
4	Control Board	1	Pc	Necessary
5	Power Supply and Cables	1	Kit	Necessary
6	Air Switch	1	Pc	Necessary
7	Card Reader and its Cable	2	Kit	Optional
8	Counter and its Cable	2	Kit	Optional
9	Top LED light and its Cable	1	Kit	Optional
10	Access Control System	1	Kit	Optional
11	Mounting Bolts	Unspecified	Pc	Necessary

## 9. Appendix

```

COM1 9600 n 8 1
Initial flag  Command      Address      BCC Verify  Terminator
buff[0] buff[1] buff[2] buff[3] buff[4]
1BYTE 1BYTE 1BYTE 1BYTE 1BYTE
0x20 0x80<Unlock> 0x01-0xfe [1]^[2] 0x03
      0x30< Lock > 0xff
      0x50<Alarm>

SW25/SW26/SW27/SW28 ID = 0000 -1111
20 80 FF 7F 03 // Normally Open
20 30 FF CF 03 // Lock
20 50 FF AF 03 // Alarm
20 81 FF 7E 03 // 1# unlock
20 82 FF 7D 03 // 2# unlock

```