

JOVISION

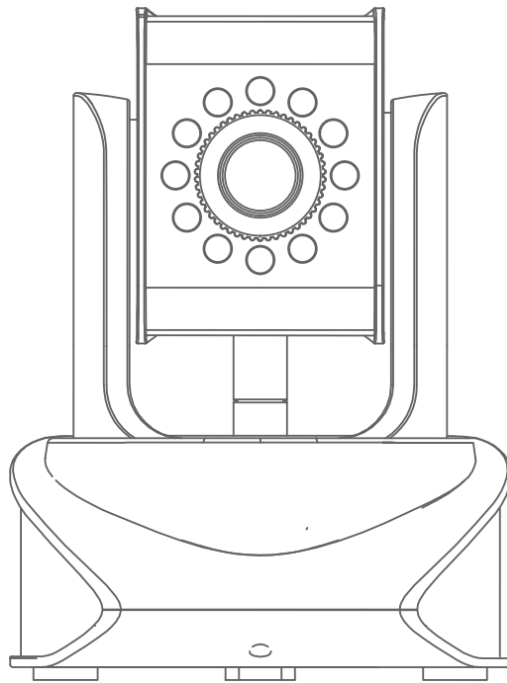

Quick Start Guide

JVS-H411

Copyright© Jovision Technology Co., Ltd.

All rights reserved.

TEL: 400-637-6777

<http://en.jovision.com>

FCC Certification Requirements

Caution: Any changes or modifications in construction of this device which are not expressly approved by the party responsible for compliance could void the user's authority to operate the equipment.

This device complies with part 15 of the FCC Rules. Operation is subject to the following two conditions: (1) This device may not cause harmful interference, and (2) This device must accept any interference received, including interference that may cause undesired operation.

The manufacturer is not responsible for any radio or TV interference caused by unauthorized modifications to this equipment. Such modifications could void the user's authority to operate the equipment.

This equipment has been tested and found to comply with the limits for a Class B digital device, pursuant to Part 15 of the FCC Rules. These limits are designed to provide reasonable protection against harmful interference in a residential installation. This equipment generates, uses and can radiate radio frequency energy and, if not installed and used in accordance with the instructions, may cause harmful interference to radio communications. However, there is no guarantee that interference will not occur in a particular installation. If this equipment does cause harmful interference to radio or television reception, which can be determined by turning the equipment off and on, the user is encouraged to try to correct the interference by one or more of the following measures:

- Reorient or relocate the receiving antenna.
- Increase the separation between the equipment and receiver.
- Connect the equipment into an outlet on a circuit different from that to which the receiver is connected.
- Consult the dealer or an experienced radio/TV technician for help.

The antenna(s) used for this transmitter must be installed to provide a separation distance of at least 20 cm from all persons.

Statement

Thank you for choosing Jovision, this user manual is intended for users of JVS-H411 network camera. It includes instructions on how to use the product. The software embodied in the product is governed by the user license agreement covering that product.

About this Manual

This Manual is subject to domestic and international copyright protection.

Jovision Technology Co., Ltd. (“Jovision”) reserves all rights to this manual. This manual cannot be reproduced, changed, translated, or distributed, partially or wholly, by any means, without the prior written permission of Jovision.

Privacy Notice

Surveillance laws vary by jurisdiction. Check all relevant laws in your jurisdiction before using this product for surveillance purposes to ensure that your use of this product conforms.

Support

Should you have any questions, please do not hesitate to contact your local dealer.

CHANGE THE DEFAULT PASSWORD

Default Network Camera Account :

Username: admin Password: 123456



The default password (123456) for the admin account is for first-time log-in purposes only. You should change this default password to better protect against security risks, such as the unauthorized access by others to the product that may prevent the product from functioning properly and/or lead to other undesirable consequences.

For your privacy, we strongly recommend changing the password to something of your own choosing (using a minimum of 8 characters, including upper case letters, lower case letters, numbers, and special characters) in order to increase the security of your product.

Proper configuration of all passwords and other security settings is the responsibility of the installer and/or end-user.

1	Introduction
1.1 Appearance and Interface	

Contents

FCC Certification Requirements	1
Statement.....	2
1. Introduction	3
1.1 Appearance and Interface	3
1.2 Specification	4
2. Installation.....	5
2.1 Ceiling Mounting.....	5
3. Network Connection	Error! Bookmark not defined.
3.1 Wireless connection.....	7
3.2 Wired Connection	7
4. Preparation on Smart Phone (iOS, Android)	8
4.1 Get CloudSEE APP.....	8
4.2 Register CloudSEE Account.....	8
4.3 Power-on the Device	8
5. Add H411 on Smart Phone (iOS, Android)	9
5.1 How to Choose Device Adding Methods.....	9
5.2 Add by Sound Wave	9
5.3 Add Wi-Fi Device on iPhone.....	11
5.4 Add Wi-Fi Device on Android	14
5.5 Add by Device ID	15
5.6 Scan devices in LAN	16
6. Alarm Device	18
6.1 Connection	18
Appendix	21
I Packing List and Qualification Card	21

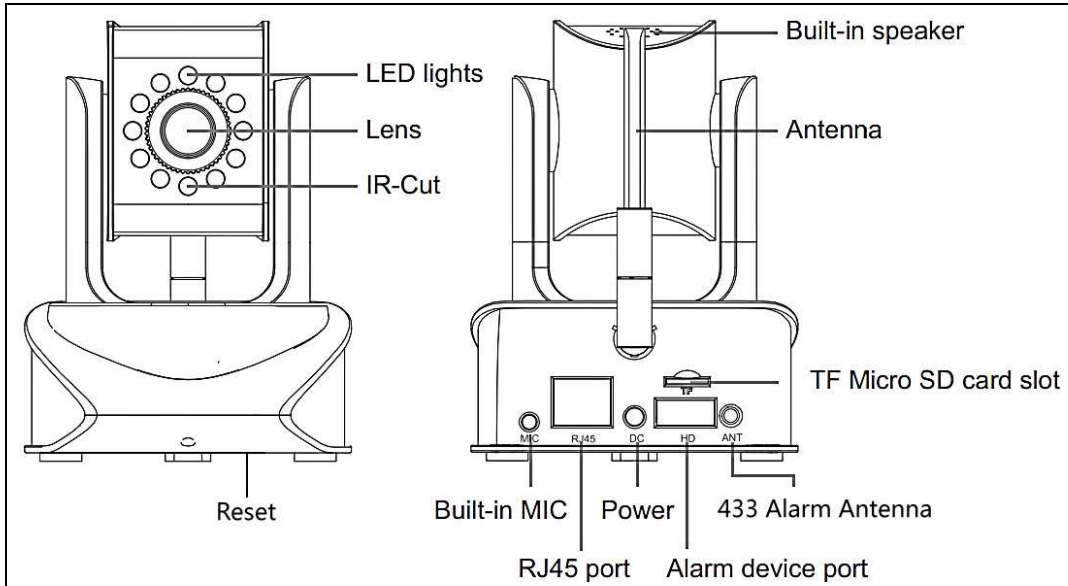

1.2 Specification

Image Sensor	1/4" CMOS
Resolution	1280×720
Pixel	1.0MP
Frame Rate	25fps
View Angle	71°
Focus	3.6mm Fixed
Local Storage	64G
Infrared Lamp	10 LED Lamps
IR distance (m)	10m
Best distance (m)	8m
Temperature	-20°C~55°C
Humidity	10%~90%
Power Supply	DC 5V
Power	≤3.2W
Material	White ABS+PC
Size(W×H×D)(mm)	95×123×122
Weight(g)	300

2 Installation

2.1 Ceiling Mounting

Before you start:

H411 can be installed to wall/ceiling or fixed on desktop. Ceiling mounting is taken as an example in this section; if you adopt wall mounting, you can also take below procedure as a reference.

Steps:

1. Attach the mounting base (not provided) to the ceiling and tighten the screws to fix it.

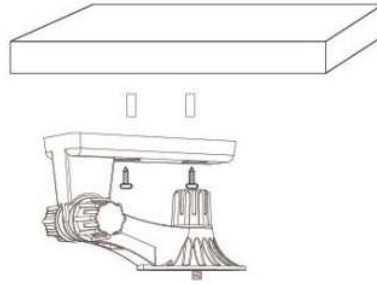

2. Use the lock screw to secure the camera on the mounting base.

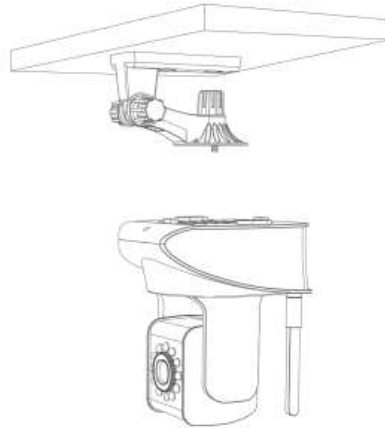

Notes:

Please make sure that the ceiling can support more than 50(N) Newton gravities if the camera is fixed to the ceiling.

3.1 Wireless connection

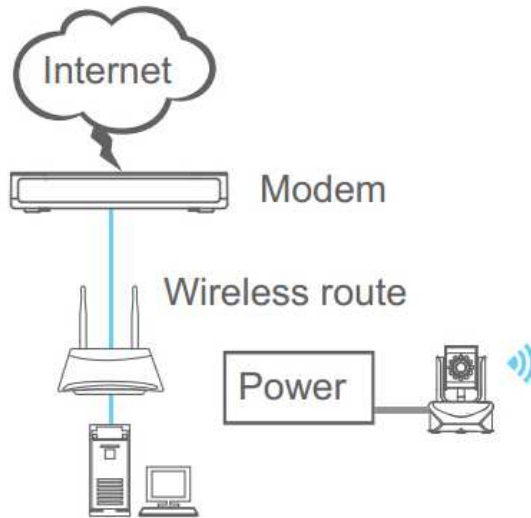

Notes:

With wireless connection, you can add the device by **“Add Wi-Fi Device”**, which is based on AP function. Once you connect H411 to the router with Ethernet cable, H411 will disable AP, which means the function mentioned above won’t work.

3.2 Wired Connection

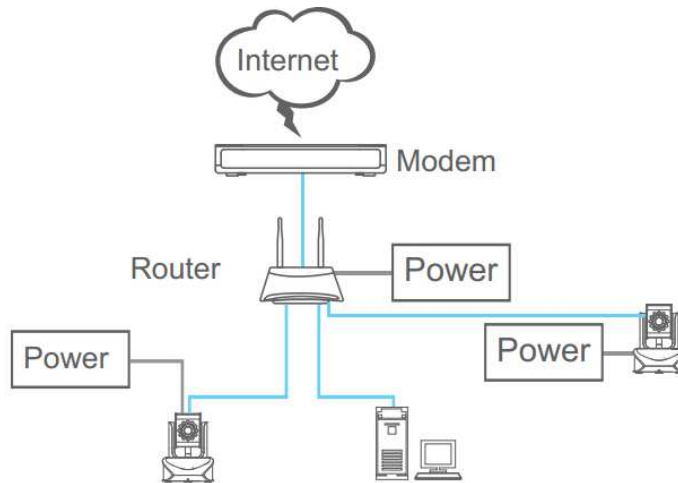

Notes:

“Add Wi-Fi Device” does not apply to wired connection.

4 Preparation on Smart Phone (iOS, Android)

4.1 Get CloudSEE APP

1. Search “CloudSEE” in App Store (iOS) or Google play (Android).
2. Get and install CloudSEE on your smart phone.

4.2 Register CloudSEE Account

Notes:

You need to register a CloudSEE account before using CloudSEE service which is free. Although you can use “**Visitor Login**”, but we strongly recommend that register your own account for better experience. With CloudSEE service account, devices list will automatically upload and store in cloud, and when you login CloudSEE with your account on other smart phones, you can access to all these devices without adding them again.

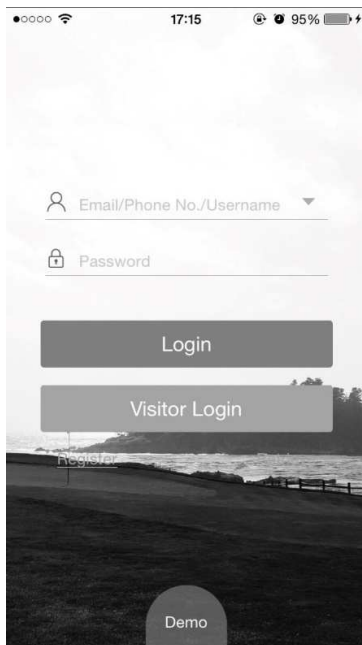

1. Open CloudSEE App, and tap “**Register**” on Login Page.

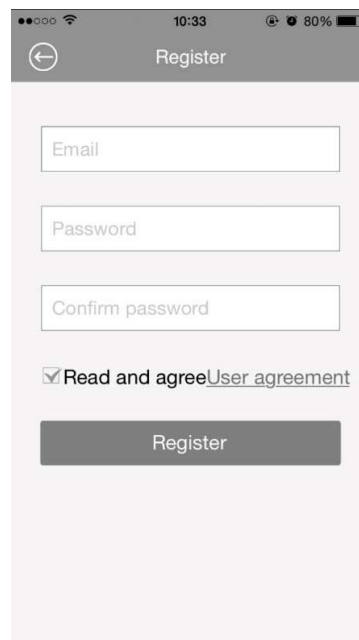

2. Input your E-mail and password, make sure the E-mail has not been registered, tap Register, account will login automatically if the register succeed.

4.3 Power-on the Device

Connect H411 with power adapter, the device starts self-checking, it will pan and tilt for about 10 seconds. After that, we can start.

5 Add H411 on Smart Phone (iOS, Android)

Before you start:

The device has to be configured by “Add by Sound Wave” or “Add Wi-Fi Device” for first-time use if you want to use wireless connection.

Press reset button for about 3 seconds and release to start sound wave configuration

Press reset button for about 15 seconds and release to reset the device.

All the operations are with audio prompts.

5.1 How to Choose Device Adding Methods

Methods	Situation	Connection
Add by CloudSEE ID	The device had been connect to Internet and get CloudSEE ID online.	Wireless, Ethernet Cable
Scan QR Code	The device had been connect to Internet and get CloudSEE ID online.(The same as “Add by CloudSEE ID”)	Wireless, Ethernet Cable
Add Wi-Fi Device	First-time use or the device has been reset.	Wireless
Scan Devices in LAN	The device has been connected to the same network as your smart phone.	Wireless, Ethernet Cable
Add by sound wave	First-time use or the device has been reset.	Wireless

5.2 Add by Sound Wave

Notes:

- Set the volume of your phone to maximum level before this operation.
- Make sure there is no noise when add the device by sound wave.
- Keep the speaker of your phone close enough to the MIC of the device when sound wave is playing

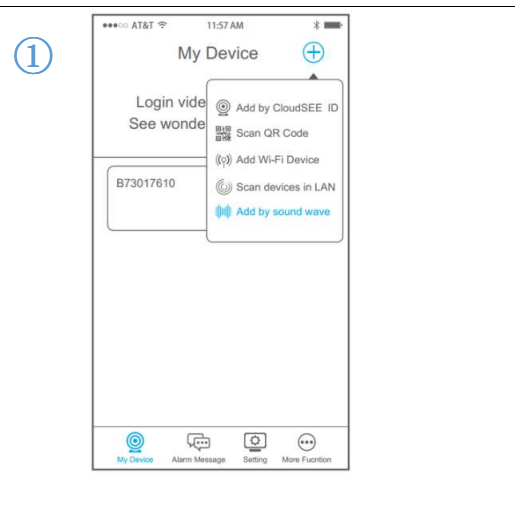

1

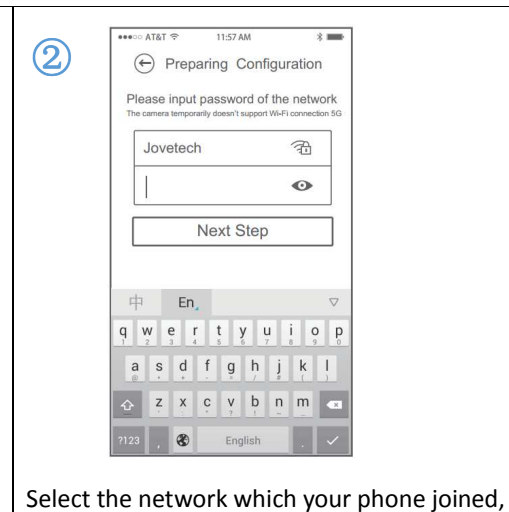

2

Select the network which your phone joined,

<p>Tap +, and select “Add by sound wave”</p>	<p>input the password and tap Next.</p>
<div data-bbox="293 258 821 840"> </div> <p>Press reset button for at least 3 seconds until hear the voice “Start voice configuration”, then release the button and tap Next</p>	<div data-bbox="821 258 1326 840"> </div> <p>There will be a demonstration with audio instructions on how to use this function. Then close the demonstration.</p>
<div data-bbox="293 968 821 1533"> </div> <p>Keep the speaker of your phone close enough to the MIC of H411, click the sound wave icon to send sound wave, you can send it for many times until hear the voice “Receive network configuration”, which means the device has joined the network.</p>	<div data-bbox="821 968 1326 1533"> </div> <p>Then CloudSEE starts scanning devices in the network. Choose the one you want to add, and click Add.</p>

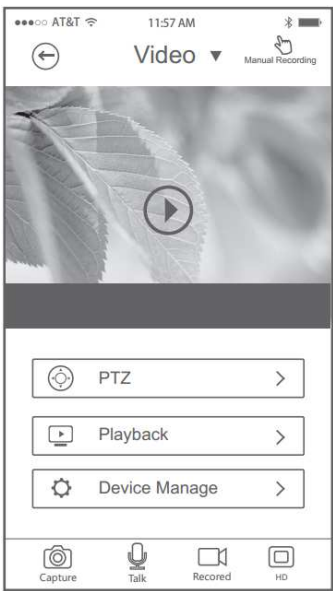
 <p>7</p> <p>The device will be added.</p>	 <p>8</p> <p>Tap the device on the list, live video will display.</p>
---	---



5.3 Add Wi-Fi Device on iPhone

Notes:

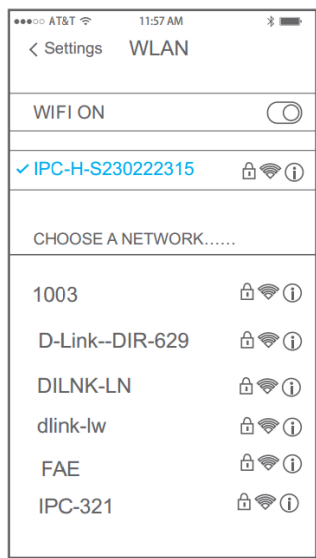
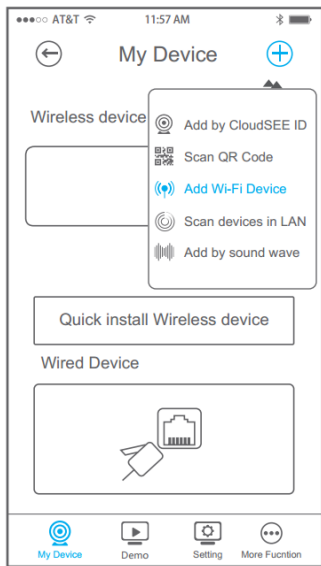
Do not connect Ethernet cable before this operation.

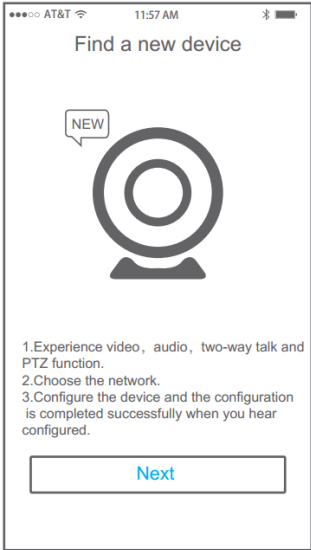
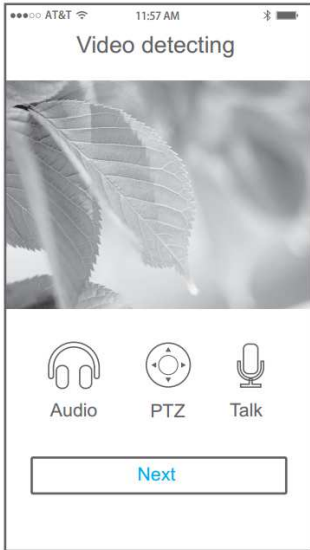
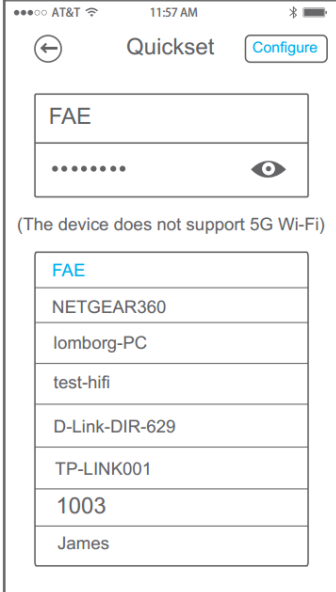
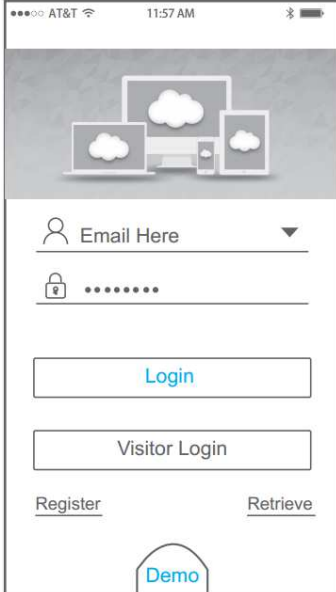
 <p>1</p> <p>Power-on the device, wait for about 40 seconds, H411 will create an AP, choose this AP (IPC-H-XXXXXXX) from the WLAN settings of your iPhone, and enter the password (12345678) when prompted.</p>	 <p>2</p> <p>Open CloudSEE App, Tap +, and select “Add Wi-Fi Device”.</p>
--	---

 <p>CloudSEE will prompt that a new device has been found. Tap NEXT.</p>	 <p>Then the live video of the device will display, you can access <i>Audio</i>, <i>PTZ</i>, <i>Talk</i> function here, but we haven't finished configuring yet, Tap NEXT.</p>
 <p>Select the Wi-Fi network for H411 and input the password, tap Configure. After hearing success from the device, you NEED to close the app and switch Wi-Fi network of your iPhone to the one which H411 is connected.</p>	 <p>When the Wi-Fi connection is completed, Open CloudSEE App again.</p>

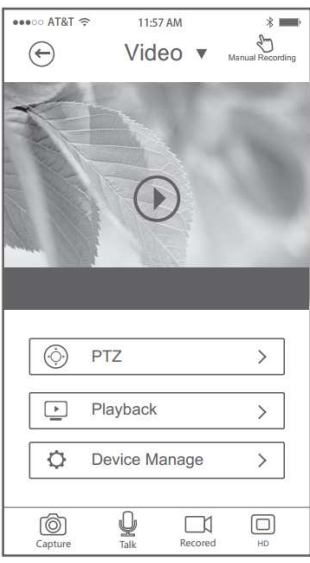
<p>7</p>  <p>CloudSEE will prompt that <i>“A new device has been configured by you”</i>, tap Add.</p>	<p>8</p>  <p>Confirm the information of the device, and tap Save</p>
<p>9</p>  <p>The device will be added.</p>	<p>10</p>  <p>Tap the device on the list, live video will display.</p>

5.4 Add Wi-Fi Device on Android

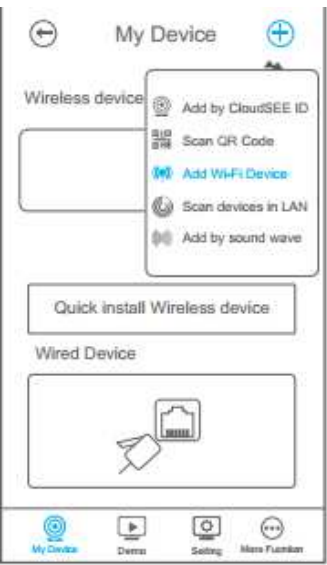

1

Open CloudSEE App, Tap ⊕, and select **“Add Wi-Fi Device”**.



2

The app will scan AP from H411 and list them, select the one you want to add. You can check whether it is the one in next step, or go back to this page to choose another.



3

Then the live video of the device will display, check the picture and confirm you can also access *PTZ*, *Two-way Talk* function here, but we haven't finished configuring yet, Tap **NEXT**.

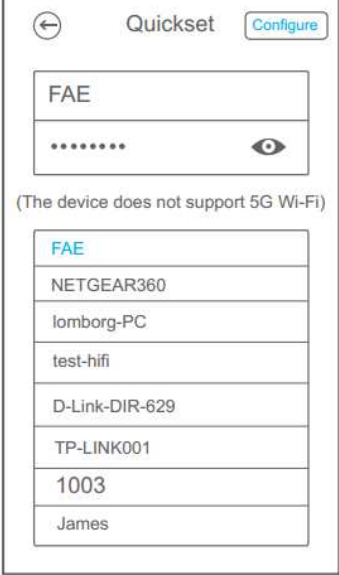

4

Select the Wi-Fi network for H411 and input the password, tap **Configure**.

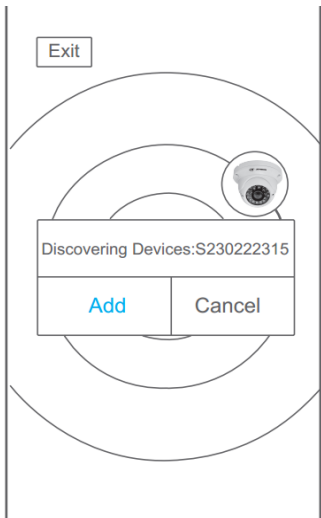
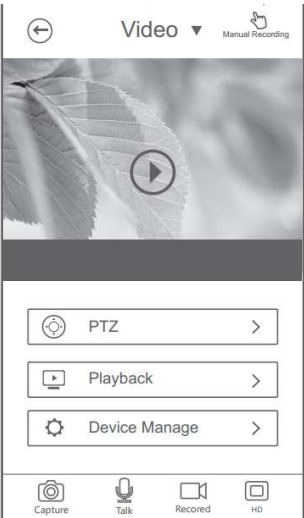
<p>5</p>  <p>Then CloudSEE will prompt that “Discovering Device”, and click Add</p>	<p>6</p>  <p>Tap the device on the list, live video will display.</p>
--	---

5.5 Add by Device ID

Notes:

This method requires that the device be connected to Internet and get CloudSEE ID online first.

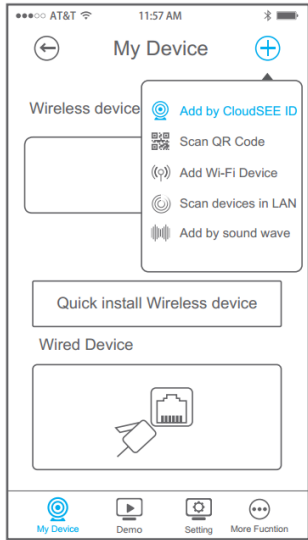
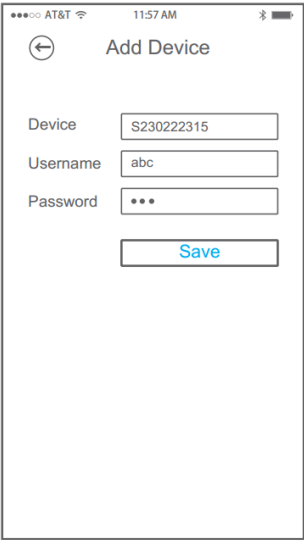
<p>1</p>  <p>Open CloudSEE App, Tap +, and select “Add by CloudSEE ID”.</p>	<p>2</p>  <p>Input <i>CloudSEE ID</i>, <i>Username</i>, <i>Password</i> of the device, tap Save</p>
---	---

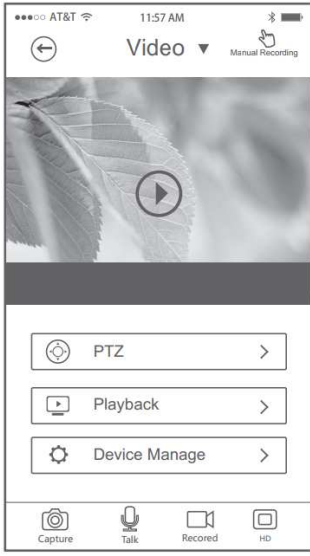
<p>③</p>  <p>The device will be added.</p>	<p>④</p>  <p>Tap the device on the list, live video will display.</p>
---	---

5.6 Scan devices in LAN

Notes:

This method requires that the device be connected to the **SAME** Wi-Fi network with your smart phone first.

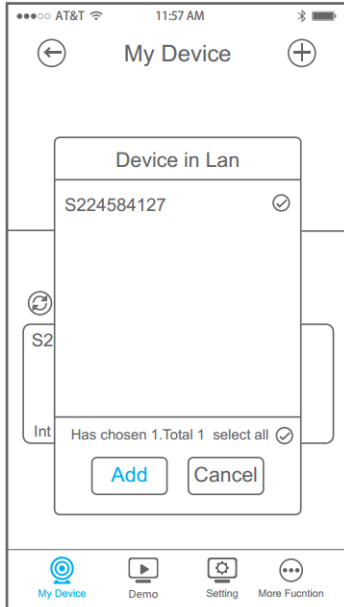
<p>①</p>  <p>Open CloudSEE App, Tap ⊕, and select “Scan devices in LAN”.</p>	<p>②</p>  <p>Then CloudSEE will detect devices in the LAN, choose the device(s) and tap Add.</p>
---	---

3

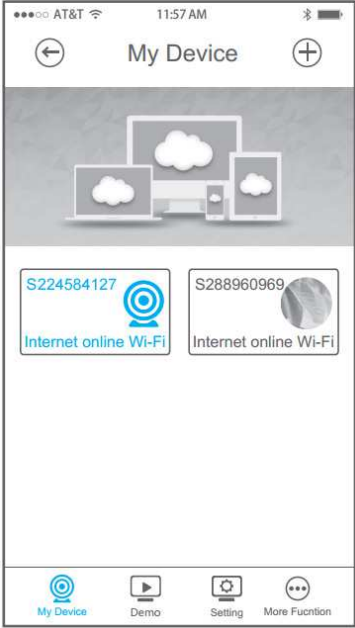

My Device

S224584127
Internet online Wi-Fi

S288960969
Internet online Wi-Fi

My Device Demo Setting More Function

4

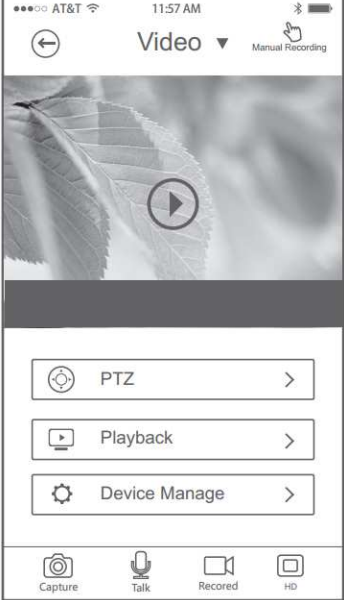

Video

Manual Recording

PTZ

Playback

Device Manage

Capture Talk Recorded HD

The device will be added.

Tap the device on the list, live video will display.

6 Alarm Device

6.1 Connection

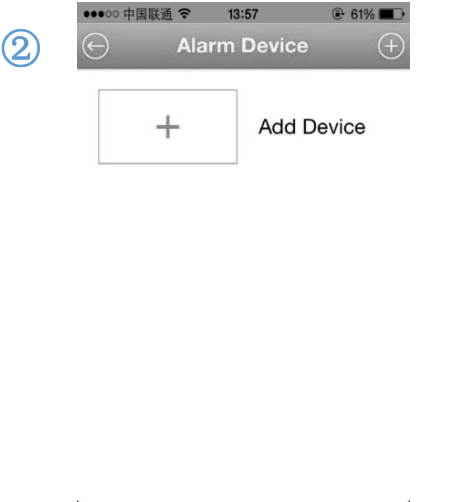
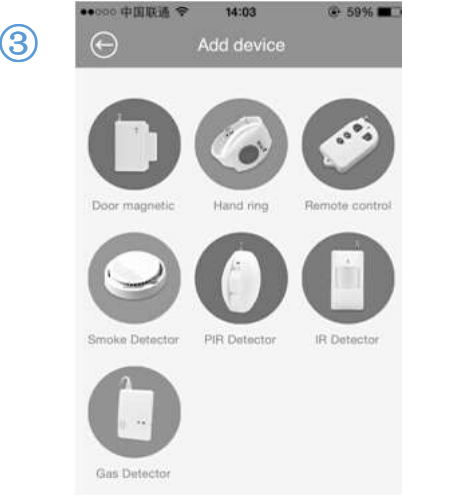
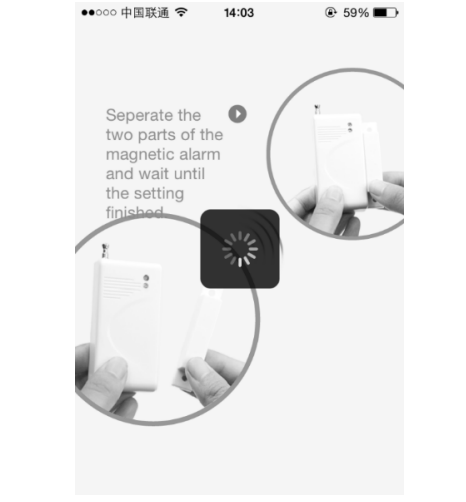
 <p>①</p> <p>Open CloudSEE App, tap Setting at the bottom of screen, and tap “Alarm Device” in Setting Page</p>	 <p>②</p> <p>Tap + to add alarm device.</p>
 <p>③</p> <p>Select the alarm devices you want to add</p>	 <p>Follow the instructions to trigger alarm device, H411 will detect and connect the alarm device automatically.</p>

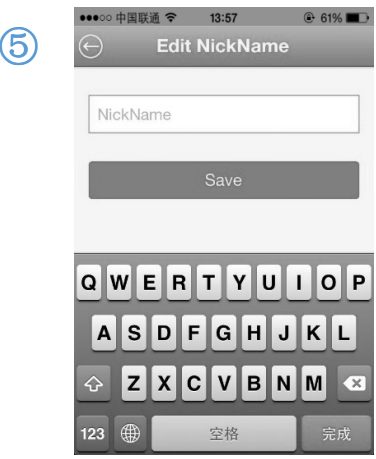
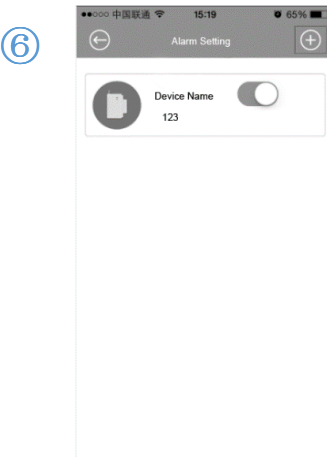
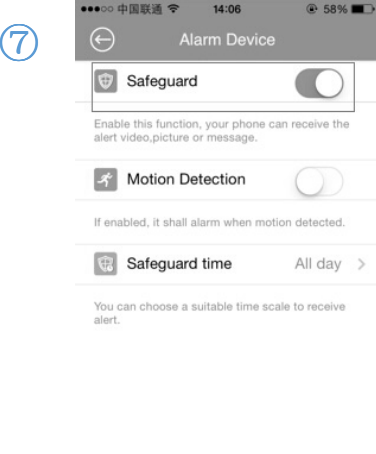
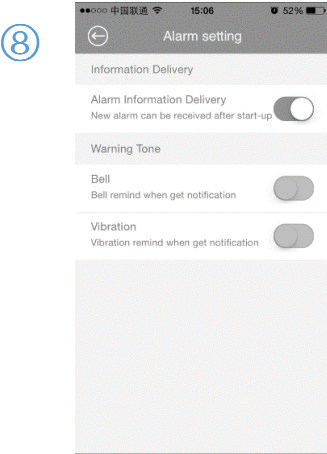
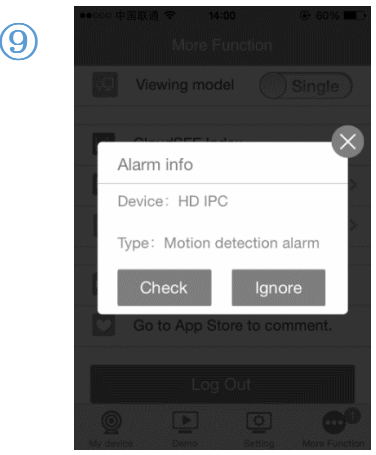
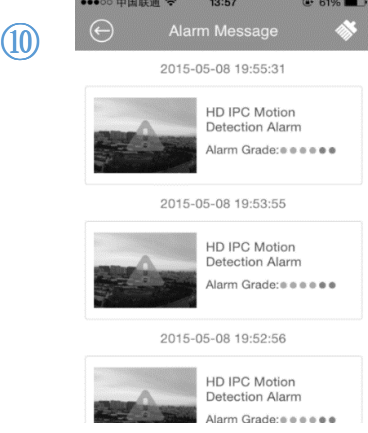
 <p>5</p>	 <p>6</p>
 <p>7</p>	 <p>8</p>
 <p>9</p>	 <p>10</p>
<p>Notes: Only after turning on all these three switch (Alarm Device, Safeguard, Information Delivery), can you receive alarm notification.</p>	

After connecting alarming device, you need to edit the name of the device.

Then you can find the alarm device just added in the list, make sure the switch is turned on.

In live video page, tap **Device set** → **Alarming set** → enable “**Safeguard**”).

In **More Function** page, tap **Alarm Setting**, enable “**Information Delivery**”.

If the alarm device is triggered, alarming notification will show. Tap **Check** for detail.

All alarming message can be checked by going to **More Function**>**Alarm Message**.

Appendix			
Packing List and Qualification Card			
No.	Component	Units	Amount
1	H411	PCS	1
2	Power Adapter	PCS	1
3	Quick Start Guide	PCS	1
4	Stand	PCS	1
Notes: Accessories may vary due to different models, please take the actual model received as standard.			

